

Seoul Office :
 Doosan Tower 27th FL. 18-12, Euljiro-6Ga,
 Jung-Gu, Seoul, Korea 100-730
 Tel : +82-2-3398-8114
 Fax : +82-2-3398-8117
www.doosaninfracore.com

Doosan Infracore Europe S.A.
 1A, Rue Achille Degrâce, 7080 Frameries, Belgium
 Tel : +32-65-61-3230 Fax : +32-65-67-7338

Doosan Infracore U.K., Ltd.
 Doosan House, Unit 6, 3 Heol Y Gamlas, Parc Nantgarw, Nantgarw,
 Cardiff. CF15 7QU, U.K.
 Tel : +44-1443-84-2273 Fax : +44-1443-84-1933

Doosan Infracore Europe S.A. Germany
 Heinrich-von-Stephan str. 2 40764 Langenfeld, Germany
 Tel : +49-2173-2035-210 Fax : +49-2173-2035-219

Doosan Infracore France
 ZAC de La Clef Saint Pierre - Buroplus 2 1A Avenue Jean d'Alembert
 78990 Elancourt, France
 Tel : +33-(0)1-30-16-21-41 Fax : +33-(0)1-30-16-21-44

Doosan Infracore America Corporation
 2905 Shawnee Industrial Way, Suwanee, Georgia 30024, U. S. A
 Tel : +1-770-831-2200 Fax : +1-770-831-0480

Doosan Infracore China Co., Ltd.
 #28, Wuzhishan Road, Eco. & Tech, Development Zone, Yantai, Shandong, China
 Tel : +86-535-638-2000 Fax : +86-535-638-2004

Doosan Infracore South Africa (PTY) LTD.
 60C Electron Road, Isando 1600, Johannesburg, South Africa
 Tel : 27-11-974-2095 Fax : 27-11-974-2778

Doosan Infracore Middle East Center (Dubai)
 P.O.Box 183127, Al-Serkal Building, Air Port Road, Dubai, U.A.E
 Tel : +971-4-295-2781~2 Fax : +971-4-295-2783

Doosan Infracore Latinamerica oficina (Colombia)
 Dia gonal 127 A No. 17-14, oficina 302 Bogota, Colombia
 Tel : +571-216-1655 Fax : +571-648-7700



PBP S340C500 0701

The illustrations do not necessary show the product in standard version.
 All products and equipments are not available in all markets.
 Materials and specifications are subjects to change without prior notice.

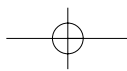

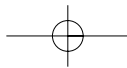

Doosan Infracore
Construction Equipment

SOLAR340LCV

Engine Power : DIN 6271,net 184kw(250ps)@1,900 rpm
 SAE J 1349,net 184kw(247HP)@1,900 rpm
Operational Weight : 33,900kg (74,700 lb)
Bucket capacity(PCSA) : 1.25 ~ 1.83m³(1.63 ~ 2.39 cu.yd)



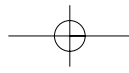

Introducing the advanced series of Solar-V excavators...

Featuring a curved exterior style appropriate to the new millennium, these machines combine whisper quiet noise levels with the smoothness of silk yet retain the Doosan tradition of great power and speed.

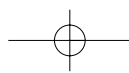

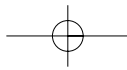

Performance

This hydraulic excavator is equipped with the air-to-air intercooler engine, which has the greatest power output in its class and excellent fuel economy. It assures outstanding workability, productivity, and efficiency through the e-EPOS system, the new and improved version of EPOS SYSTEM. This will assure increase in operating capacity and decrease in fuel consumption.

Improved maneuverability and control

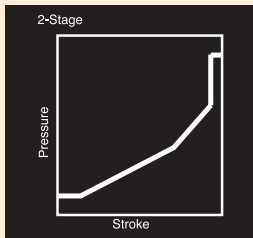

New technologically advanced control valve and joystick valves have been installed to allow speedy, smooth and responsive control.

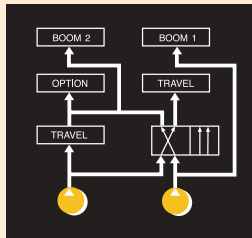

Advanced hydraulic circuit separates the oil flow for travel and boom function to allow precise and safe operation when handling loads during travel.

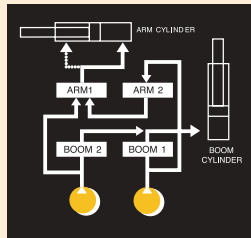

The circuits for the boom, arm, and bucket have been improved to assure smooth and confident control during combination.

Air to Air Intercooler Engine

Greatest power output and high-efficiency engine in it's class.



Environmentally friendly, Green engine

This machine is equipped with the engine meeting the U.S. EPA Tier-II Regulations and European stage-II Regulations requiring the reduction of harmful NOx, PM, HC, and CO emissions.

Joystick grip with 2 switches
Spare switches are installed on both joystick grips to control the additional attachment.



Compatible with the European New Noise Control Requirements

To reduce the fan rotations and resulting noise, a large-capacity new fan blade has been installed. In addition, low noise muffler has been adopted to easily satisfy the new European Noise control requirements and improve noise levels.

Improved stability

Weight redistribution and increased swing radius (+165mm) improved dynamic stability and side lifting power. The stiffer frame of superstructure has greatly reduced structural vibration during operation.

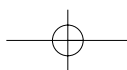

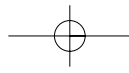

Working Environment

Wide operator cabin space meeting the ISO Standards and expanded all-round visibility. The low-noise, low-vibration type comfortable cabin provides the operator with safe and ergonomic operating environment.



Good visibility
The enlarged right-hand glass and the minimized crosswise strut in windshield have been achieved to increase the visual range by 15% when compared to the previous machine.



Large ceiling cover
The ceiling cover can be opened to confirm the bucket operation even at the maximum excavating height. (Visual range increased by 25% compared to previous machine.)



Long wind shield wiper blade
Front visibility is further improved by using the lengthened wiper blade (wiper area increased 35% compared to previous machine.)



Increased foot space
Instruments, controls, and accessories have been ergonomically located in the cabin and 300mm seat slide has been achieved to provide ample space for operator's feet and legs.

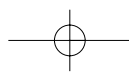

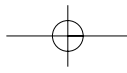

Cup holder
A folding style cup holder has been installed in the cabin allowing the operator to easily store a can or cup.



12V Spare Power Socket
This socket can be used for charging a cellular phone or powering a small 12V DC electrical device.

Low Vibration Cab Mounting System

By using a total isolating seal design (full sealing) outside noise has been drastically reduced to the levels comparable to that in a modern car. A viscous sealed mounting system has been incorporated, and the frame, cabin and seat have been designed to absorb major and minor vibrations, resulting in a significant decrease in vibration felt by the operator.

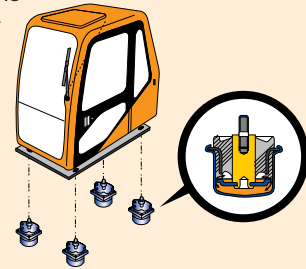

Fresh Air Type Air Conditioner

One touch selector switch for the air conditioner and heater output, featuring a multi-vent circulation system that allows for greater cooling / heating performance. Improved front window defroster system has been added to provide enhanced clarity and visibility during any working condition.

- Easy replaceable air filter.
- Larger cool air intake vents.
- Industry standard fresh air/recirculation control system incorporated.
- Modular electric fan condenser compartment.

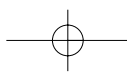
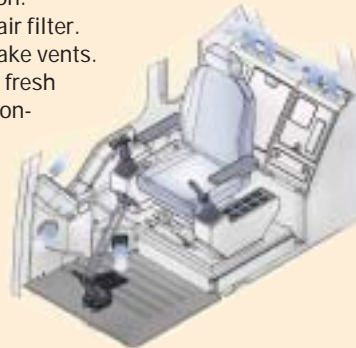

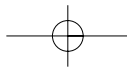

Maintenance

Quick and easy service checks, maximize the excavator's life expectancy.

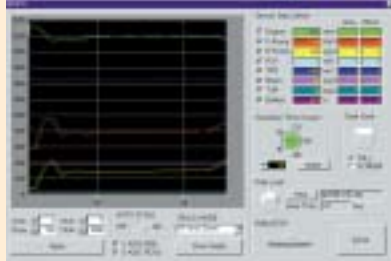

PC monitoring function (SMS)

By connecting a laptop PC to the controller (e-EPOS controller) of the machine, data such as pump pressure and engine RPM can be displayed graphically. Also other various machine status data can be stored in memory and printed out using a printer.



Water separator

The transparent glass water separator is mounted at a location easily accessible from the ground allowing easy maintenance of the fuel system.



Easy radiator cleaning

The clearance between the oil cooler and radiator has been widened for easy insertion of the air nozzle during cleaning.



Easy installation for the 3rd pump

The PTO mountable pump has been installed permitting easy mounting of the 3rd pump.



Engine oil drain valve

The engine oil drain valve with quick coupler provides fast and environmentally sound serviceability.



Electrical control access box

Pull-out style drawer for electrical control access box allows for easy service and maintenance.

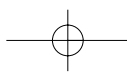

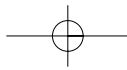

Graphic display LCD Monitor panel

The information monitor panel displays both text and symbols for easy recognition of machine status and various other data



Real-time clock with day / date

The real-time clock displays date and day in easy to read format.

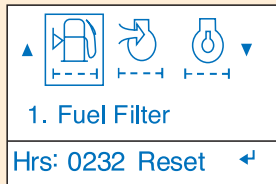

Filter / oil operating hour display

The hours in use for 9 filters and oils can be displayed so that replacement intervals can be easily recognized.

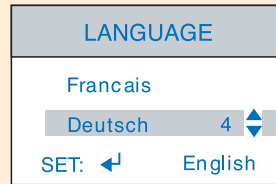

Multiple language display

The user menu can be displayed in multiple languages for the operator's convenience.

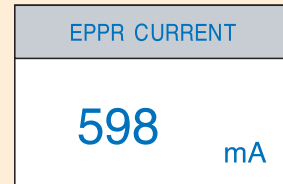

Real-time machine data display

Displays 28 different machine status data and information such as pump delivery pressure and engine RPM.

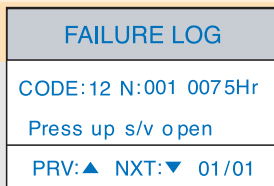

Self-diagnosis and fault history memory functions

Current faults and past faults history of the excavator control system are displayed and memorized on a real-time basis to enable correct diagnosis and quick repair.

Simplified operation mode selection

The 3 work modes from the previous models have been reduced to digging and trenching modes for easy selection.

- Digging Mode : General Excavating, Ground Leveling, Loading Dump Truck, allows for versatility.
- Trenching Mode : trenching or excavating of side wall, operations which require heavy swing work.

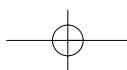



Excellent Reliability

Doosan's world-class center for product reliability performs sophisticated testing on all completed products, to ensure they meet or exceed market standards.



Larger rubber pipe clamps

Larger size and improved material pipe clamps have been installed. This has resulted in noise reduction, increased vibration absorption and durability characteristics as well as preventing pipe cracks.



Rubber coated wire harness clamps

Electric wire harnesses have been mounted with rubber coated clamps to decrease vibration damage.



Emergency throttle cable

In the event of engine speed control dial malfunction, emergency throttle cable mounted in the cabin can be used to manually control engine speed.

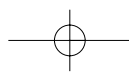

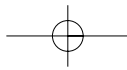

Strengthened Boom

Through stress analysis and endurance testing, the boom frame's rear/ central sections have been manufactured for the optimum life expectancy by using unibody casting to prevent cracking.

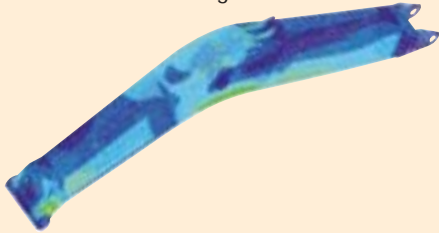

Arm Assembly

Critical components have been strengthened through stress analysis. All areas around the boss have castings and are reinforced resulting in additional durability and strength.

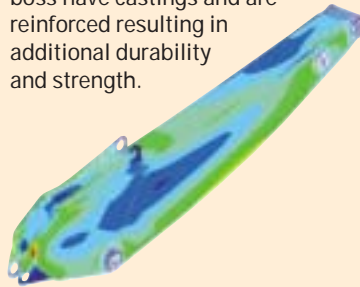

Reinforced frame

Both boom and counterweight attaching sections have been reinforced to realize high-rigidity. As a result, the frame can support the long front and heavy attachments easily and ensure safe maneuverability. The right and left frame have been more stiffened by larger cross sections.

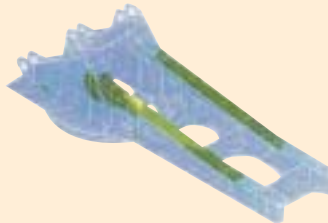

Greased and sealed track link (option)

The track pins and bushings are greased and sealed to reduce noise during travel and dramatically extend the track life span.

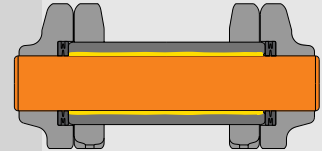

Brushless type alternator

The semi-permanent alternator, resistant to dust and other pollutants for heavy-duty applications has been installed.



Heat shield panel for turbo charger

The heat shield guard has been installed over the turbo charger to prevent the operator from inadvertently touching the hot surfaces while checking the engine area.



Large handrail

The large handrail meeting the ISO Standards enables the operator to gain safe access to the section to be serviced.



360° fan guard

A metal mesh guard has been installed all around the fan blade to prevent accidental bodily injury.

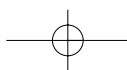

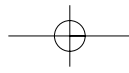

Technical Data

Engine

Model	DOOSAN DE12TIS
Type	Water-cooled, 4-cycle, direct injection .
Aspiration	Turbocharged Air-to-Air Intercooler
No. of cylinders	6
Rated flywheel horse power	
DIN 6271, net	184KW (250PS) at 1,900 rpm
SAE J1349, net	184KW (247HP) at 1,900 rpm
Piston displacement	11,051cc (675cu.in)
Maximum torque	108kgf.m (1059Nm, 781lb.ft.) @1,400 rpm
Bore and stroke	123mm × 155mm (4.8" × 6.1")
Starting system	24V Electric motor
Batteries	2 × 12V × 150 AH

Hydraulic system

e-EPOS-V (Electronic Power Optimizing System) allows the operator to maximize work efficiency over a full range of operating conditions and to minimize fuel consumption.

- Hydraulic system assures fully independent and combined operations.
- Automatic 2 speed travel system for high traction force and travel speed.
- Cross-sensing and fuel saving pump system.
- Auto idle system.
- 2-Working / 2-power mode selection system.
- Computer aided engine-pump control.

Main pumps	2 variable displacement axial piston pumps.
Max. oil flow	2 × 266 ℓ/min (2 × 70.3US gpm, 2 × 58.5Imp gpm)
Pilot pump	Gear pump
Max. oil flow	22.5 ℓ/min (5.9US gpm, 4.9 Imp gpm)
Swing motor	
Relief valve	266 bar (3,780 psi, 270kgf/cm ²)

Main relief valves

Boom/Arm/ Bucket	Normal : 324bar (4,690 psi, 330kgf/cm ²) Power Boost : 343bar (4,970 psi, 350kgf/cm ²)
------------------------	---

Travel circuit

	324 bar (4,690 psi, 330kgf/cm ²)
--	--

Hydraulic cylinders

High-strength piston rods and tubes are used. Cylinder cushion mechanism is provided for all cylinders to assure shock-free operation and extend life of cylinder.

Cylinders	Q'ty	Bore × Rod dia. × Stroke
Boom	2	150 × 100 × 1440mm (5.9" × 3.9" × 56.7")
Arm	1	170 × 115 × 1812mm (6.7" × 4.5" × 71.3")
Bucket	1	150 × 100 × 1300mm (5.9" × 3.9" × 51.2")

Super-structure revolving frame

A deep, full-reinforced box section. Heavy-gauge steel plates used for ruggedness.

Operator's cab

A roomy, independent, shock and noise-free operator's cab, 4 side safety glass windows give all-round visibility. Front window slides up and stores in the roof and side window can be left open for ventilation. Fully adjustable reclining seat : fwd./rev. and up/down. Cab cooler(option). ISO standard cab. Noise Levels (dynamic value)

L_{WA} External noise

Guaranteed Sound Power Level	106 dB (A) (2000/14/EC)
Measured Sound Power Level	106 dB (A) (2000/14/EC)

L_{pA} Operator noise

76 dB (A) (ISO 6396)

Controls. 2 implement levers

Pilot pressure control type. Right lever is boom and bucket control, left lever for swing and arm control.

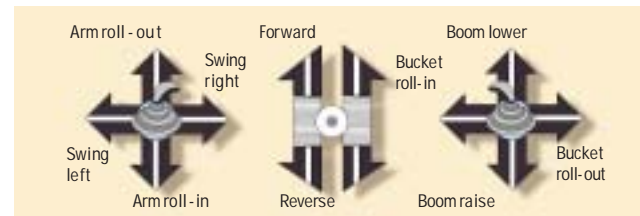

2 Travel pedals with levers

Pilot pressure control type. Independent drive at each track allows counter-rotation of the tracks. Levers are detachable.

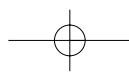

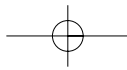

Swing mechanism

High-torque, axial piston motor with planetary reduction gear bathed in oil. Swing circle is singlerow, shear type ball bearing with induction-hardened internal gear. Internal gear and pinion gear immersed in lubricant. Swing parking brake is spring-set, hydraulic-released disc type.

- Swing speed0 to 8.9rpm(min⁻¹)
- Rear swing radius3,500mm(11' 6")



Drive

Each track is driven by an independent, high-torque, axial piston motor through planetary reduction gear. Two levers or foot pedal control provide smooth travel or counter-rotation upon demand.

Travel speed (High / Low)..... 4.6/ 3.1km/h
(2.9/ 1.9 mph)

Maximum traction force27,800 kgf (61,300 lbf)

Gradeability 35° (70%) continuous



Undercarriage

Tractor type undercarriage. Heavy-duty track frame, all welded stress-relieved structure. Top grade materials are used for toughness. Side frames are welded, securely and rigidly, to the track frame. Lifetime-lubricated track rollers, idlers and sprockets with floating seals. Track shoes of induction-hardened rolled alloy with triple grousers. Specially heart-treated connecting pins. Hydraulic track adjusters with shock-absorbing recoil springs.

Number of rollers and shoes (each side) ground contact area

- Upper rollers 2
- (Standard shoe)
- Lower rollers 9
- Track shoes 51
- Overall track length 4,960 mm(16' 3")



Brake

Two oil disc brake on final drive input shafts. Parking brake is spring-set, hydraulic-released disc type.



Weight

Equipped with 6.5m(21'3")boom, 3.2m(10'5")arm, and 1.48m³(1.94yd³; PCSA heaped) bucket and 600mm(24") shoes.

Shoe type	Shoe width	Operating weight	Ground pressure
Triple grouser	600mm (24")	33,900 kg (74,700lb)	0.65kg/cm ² (63kpa, 9.2psi)
	700mm (28")	34,300kg (75,600lb)	0.56kg/cm ² (55kpa, 8.0psi)
	800mm (32")	34,700kg (76,500 lb)	0.50kg/cm ² (49kpa, 7.1psi)
	850mm (34")	34,900 kg (76,900 lb)	0.47kg/cm ² (46kpa, 6.7psi)



Service refill capacities

	Liters	US gal	Imp gal
Fuel tank	550.0	145.3	121.0
Cooling system	58	15.3	12.8
Lubrication	Liters	US gal	Imp gal
Engine oil	28.0	7.3	6.1
Swing drive (each)	6	1.6	1.3
Final drive (each)	5.5	1.4	1.2
Hydraulic system	460	121.5	101.2
Hydraulic tank	210	55.5	46.2

Buckets

Capacity		Width		Weight	Recommendation		
PCSA, heaped	CECE, heaped	Without side cutters	With side cutters		2.6m (8'6")Arm	3.2m (10'6")Arm	4.0m (13'11")Arm
1.25m ³ (1.63yd ³)	1.1m ³	1,228mm (48")	1,273mm (50")	1,233 kg (2,720 lb)	A	A	B
1.48m ³ (1.93yd ³)	1.3m ³	1,410mm (56")	1,456mm (57")	1,340 kg (2,955 lb)	A	B	B
1.61m ³ (2.10yd ³)	1.4m ³	1,500mm (59")	1,546mm (61")	1,399 kg (3,085 lb)	A	B	B
1.83m ³ (2.39yd ³)	1.6m ³	1,678mm (66")	1,723mm (68")	1,514 kg (3,340 lb)	A	B	C

A. Suitable for materials with density of 2,000 kg/m³ (3,690 lb / cu.yd) or less
 B. Suitable for materials with density of 1,600 kg/m³ (1,160 lb / cu.yd) or less
 C. Suitable for materials with density of 1,100 kg/m³ (2,030 lb / cu.yd) or less

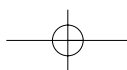

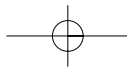

Dimensions & Working Ranges

Dimensions (6.5m(21' 4") Boom, 3.2m(10' 6") Arm, 600mm(24") Shoe)

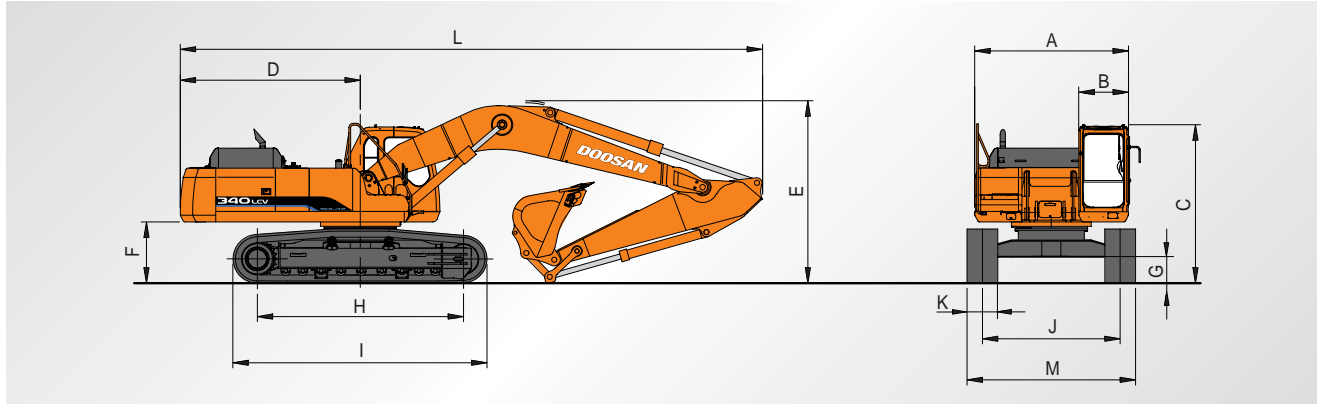

	S340Lc-v	S340NLc-v
A Overall width of upper structure	2,990mm(9'10")	2,990mm(9'10")
B Overall width of cab	960mm(38")	960mm(38")
C Overall height of cab	3,080mm(10'1")	3,080mm(10'1")
D Tail swing radius	3,500mm(11'6")	3,500mm(10'11")
E Overall height	3,550mm(11'8")	3,550mm(11'8")
F Clearance under counterweight	1,195mm(3'11")	1,195mm(3'11")
G Ground clearance	506mm(19'9")	506mm(19'9")
H Tumbler distance	4,010mm(13'2")	4,010mm(13'2")
I Track length	4,960mm(16'3")	4,960mm(16'3")
J Track gauge	2,680mm(8'10")	2,400mm(7'10")
K Track shoe width	600mm(24")	600mm(24")
L Overall length	11,330mm(37'2")	11,330mm(37'2")
M Overall track width with 600mm (24") shoe	3,280mm(10'9")	3,000mm(9'10")

Working ranges

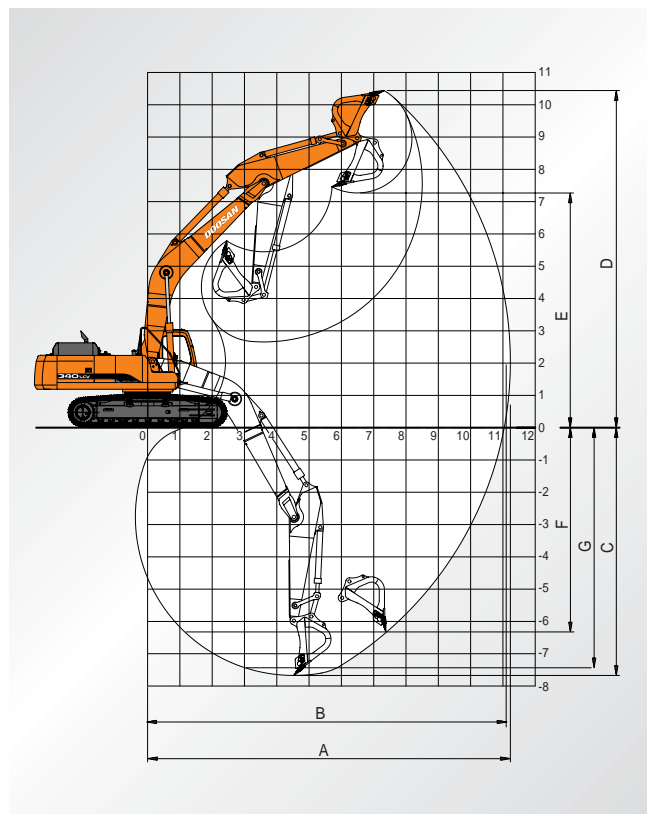

Digging forces (Maximum radial tooth forces)

	2.6m (8' 6") Arm	3.2m (10' 6") Arm	4.0m (13' 1") Arm
Bucket digging force *	21,800kgf	21,800kgf	21,800kgf
	213kN	213kN	213kN
	48,000lbf	48,000lbf	48,000lbf
Arm digging force *	21,200kgf	17,400kgf	14,900kgf
	207kN	170kN	146kN
	46,600lbf	38,400lbf	32,900lbf

*At power boost

Boom length	6.5m (21'4")		
Arm length	2.6m (8'6")	3.2m (10'6")	4.0m (13'1")
A. Max. digging reach	10,620mm (34'10")	11,230mm (36' 10")	11,990mm (39' 4")
B. Max. digging reach at ground level	10,420mm (34'2")	11,040mm (36' 3")	11,810mm (38' 9")
C. Max. digging depth	7,070mm (23'2")	7,670mm (25' 2")	8,480mm (27' 10")
D. Max. digging height	10,010mm (32'10")	10,440mm (34' 3")	10,820mm (35' 6")
E. Max. dumping height	6,890mm (22'7")	7,270mm (23' 10")	7,640mm (25' 1")
F. Max. vertical wall digging depth	5,320mm (17'6")	6,200mm (20' 4")	6,990mm (22' 11")
G. Max. digging depth (8' level)	6,860mm (22'6")	7,510mm (24' 8")	8,340mm (27' 4")

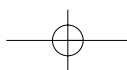

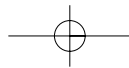

Standard & Optional Equipment

SOLAR **340 LCV**

Standard equipment

Hydraulic system

- Boom and arm flow regeneration
- Boom and arm holding valves
- Spare ports (valve)
- One-touch power boost

Cabin & Interior

- Viscous cab mounts
- All weather sound suppressed type cab
- Air conditioner
- Adjustable suspension seat with head rest and adjustable arm rest
- Pull-up type front window and removable lower front window
- Room light
- Intermittent windshield wiper
- Cigarette lighter and ashtray
- Cup holder
- Hot & cool box
- Graphic display monitor
- Fuel control dial
- AM/FM Radio and cassette player
- Remote radio ON/OFF switch
- 12V spare power socket
- Serial communication port for laptop PC interface
- Joystick lever with 2 switches

Safety

- Large handrails and step
- Punched metal anti-slip plates
- Seat belt
- Hydraulic safety lock lever
- Safety glass
- Hammer for emergency escape
- Right and left rearview mirrors
- 360 degree fan guard

Others

- Double element air cleaner
- Pre-cleaner
- Water separator
- Dust screen for radiator
- Engine overheat prevention system
- Engine restart prevention system
- Self-diagnostic system
- Alternator (24V, 50 amps)
- Electric horn
- Halogen working lights (frame mounted 2, boom mounted 2)
- Hydraulic track adjuster
- Track guards

Optional equipment

Safety

- Boom and arm hose rupture protection valve
- Overload warning device
- Cabin Top/Front guard (ISO 10262, FOGS standard)
- Travel alarm
- Travel & swing alarm
- Rotating beacon

Cabin & Interior

- Sunvisor
- Sun roof
- Joystick lever with 3 switches

Others

- 3m narrow gauge track
- Piping for hammer (one way)
- Double fuel filter
- Greased and sealed track link
- Additional work lights on the cabin (① 2 front lamps, ② 4 front and 2 rear lamps)
- Large capacity alternator (24V, 80A)
- Electric fuel supply pump



Boom and arm hose rupture protection valve



Sunvisor



Additional work lights on the cabin



Electric fuel supply pump



Rotating beacon

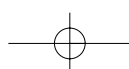

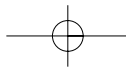

Lifting Capacities

Standard

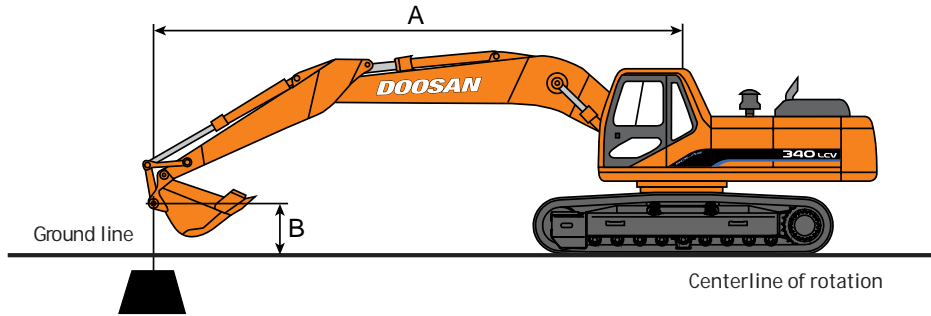

Boom : 6.5m (21'4")
 Arm : 3.2m (10'5")
 Bucket : PCSA 1.49m³ (CECE 1.3m³)
 Shoe : 600mm (24")

Metric

Unit : 1,000 kg

A (m) \ B (m)	2		3		4		5		6		7		8		9		Max. Reach			
	☐	☐☐	☐	☐☐	☐	☐☐	☐	☐☐	☐	☐☐	☐	☐☐	☐	☐☐	☐	☐☐	☐	☐☐	A(m)	
7													*6.11	*6.11				*6.13	5.69	8.31
6													*6.24	6.06				*6.21	5.04	8.84
5												*6.88	*6.88	*6.56	5.96	*6.38	4.82	*6.37	4.60	9.23
4							*9.69	*9.69	*8.39	*8.39	*7.56	7.28	*7.00	5.83	*6.63	4.75	*6.51	4.31	9.50	
3					*14.97	*14.97	*11.47	*11.47	*9.52	9.01	*8.30	7.06	*7.49	5.69	*6.94	4.66	6.41	4.12	9.65	
2					*17.56	16.24	*13.10	11.48	*10.60	8.69	*9.04	6.85	*7.99	5.55	7.11	4.57	6.29	4.02	9.70	
1					*16.12	15.72	*14.36	11.10	*11.51	8.43	*9.69	6.67	*8.44	5.42	7.02	4.49	6.29	4.01	9.64	
0			*8.24	*8.24	*16.30	15.47	*15.14	10.86	*12.16	8.24	*10.18	6.53	8.36	5.32	6.95	4.42	6.41	4.08	9.47	
-1	*8.21	*8.21	*11.38	*11.38	*18.51	15.39	*15.46	10.73	*12.51	8.12	10.20	6.44	8.28	5.26	6.91	4.39	6.69	4.24	9.20	
-2	*11.59	*11.59	*14.89	*14.89	*19.40	15.40	*15.36	10.70	*12.54	8.07	10.16	6.40	8.26	5.23			7.15	4.54	8.79	
-3	*15.13	*15.13	*18.93	*18.93	*18.52	15.50	*14.86	10.73	*12.22	8.09	10.17	6.41	8.28	5.26			7.91	5.03	8.25	
-4	*19.11	*19.11	*21.77	*21.77	*17.13	15.67	*13.89	10.84	*11.46	8.16	*9.51	6.48					*8.54	5.83	7.53	
-5	*23.82	*23.82	*18.86	*18.86	*15.06	*15.06	*12.29	11.02	*10.05	8.32							*8.54	7.26	6.58	
-6			*14.71	*14.71	*11.92	*11.92	*9.59	*9.59									*8.97	*8.97	5.27	

Feet

Unit : 1,000 lb

A (ft) \ B (ft)	10'		15'		20'		25'		30'		Max. Reach		
	☐	☐☐	☐	☐☐	☐	☐☐	☐	☐☐	☐	☐☐	☐	☐☐	A(ft)
25'							*13.35	*13.35			*13.50	*13.50	25' 11"
20'							*13.76	*13.76			*13.67	11.22	28' 10"
15'					*17.00	*17.00	*15.16	14.15	*14.23	10.27	*14.17	9.83	30' 80"
10'	*23.58	*23.58	*27.75	*27.75	*20.57	19.41	*17.06	13.60	*15.12	10.00	14.14	9.09	31' 80"
5'			*34.01	28.52	*23.96	18.42	*18.97	13.06	15.18	9.72	13.83	8.82	31' 90"
0	*18.76	*18.76	*37.20	27.50	*26.31	17.73	19.88	12.65	14.95	9.51	14.14	8.98	30' 10"
-5'	*29.54	*29.54	*37.62	27.19	*27.21	17.41	19.64	12.44			15.22	9.66	29' 60"
-10'	*42.79	*42.79	*35.79	27.33	*26.41	17.41	19.66	12.45			17.54	11.15	27' 00"
-15'	*44.06	*44.06	*31.40	27.84	*23.28	17.74					*19.23	14.39	23' 00"
-20'	*31.03	*31.03	*22.48	*22.48							*19.75	*19.75	16' 90"

- Note
1. Ratings are based on SAE J1097
 2. The load point is a hook located on the back of the bucket.
 3. *Rated loads are based on hydraulic capacity.
 4. Rated loads do not exceed 87% of hyd. Capacity or 75% of tipping capacity.

- ☐ : Rating over front
- ☐☐ : Rating over side or 360 degree
- 0 : Ground

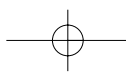

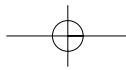

SOLAR 340 LCV

Option

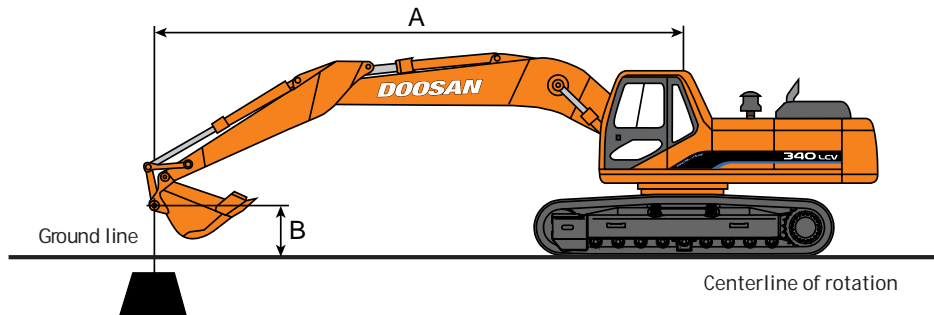

Boom : 6.5m (21'4")
 Arm : 2.6m (8'6")
 Bucket : PCSA 1.83m³ (CECE 1.6m³)
 Shoe : 600mm (24")

Metric

Unit : 1,000 kg

A (m) \ B (m)	2		3		4		5		6		7		8		9		Max. Reach			
	☐	☐☐	☐	☐☐	☐	☐☐	☐	☐☐	☐	☐☐	☐	☐☐	☐	☐☐	☐	☐☐	☐	☐☐	A (m)	
7											*6.53	*6.53						*6.55	5.76	7.51
6											*6.81	6.48	*6.64	5.07				*6.63	4.96	8.09
5									*7.96	*7.96	*7.30	6.33	*6.89	5.00				*6.76	4.44	8.52
4					*13.57	*13.57	*10.60	10.59	*8.96	7.92	*7.93	6.15	*7.27	4.88				*6.92	4.09	8.81
3					*16.59	14.12	*12.30	10.08	*10.02	7.61	*8.62	5.95	*7.71	4.76				6.97	3.88	8.97
2					*14.40	13.44	*13.75	9.64	*10.99	7.33	*9.28	5.77	*8.14	4.64	6.86	3.78		6.83	3.77	9.02
1					*13.65	13.14	*14.73	9.35	*11.75	7.11	*9.82	5.62	8.21	4.54				6.74	3.75	8.96
0					*16.14	13.05	*15.21	9.19	*12.22	6.97	10.05	5.51	8.13	4.46				7.01	3.83	8.78
-1			*12.47	*12.47	*19.27	13.06	*15.24	9.13	*12.38	6.90	9.98	5.44	8.08	4.42				7.38	4.03	8.48
-2	*14.07	*14.07	*17.50	*17.50	*18.52	13.14	*14.89	9.14	*12.20	6.89	9.97	5.43	8.09	4.43				8.02	4.39	8.04
-3	*18.79	*18.79	*21.65	*21.65	*17.34	13.27	*14.11	9.22	*11.64	6.94	*9.67	5.48						*8.89	5.00	7.44
-4	*24.14	*24.14	*19.28	*19.28	*15.61	13.48	*12.81	9.37	*10.54	7.06								*9.24	6.06	6.64
-5			*15.90	*15.90	*13.05	*13.05	*10.68	9.61										*9.50	8.23	5.53

Feet

Unit : 1,000 lb

A (ft) \ B (ft)	10'		15'		20'		25'		Max. Reach			
	☐	☐☐	☐	☐☐	☐	☐☐	☐	☐☐	☐	☐☐	A (ft)	
25'									*14.40	14.32	23' 20"	
20'								*14.68	12.28	*14.60	11.07	26' 50"
15'						*18.24	17.39	*15.89	11.91	*15.04	9.42	28' 50"
10'				*30.14	25.51	*21.62	16.40	*17.61	11.42	15.40	8.57	29' 50"
5'				*35.43	23.90	*24.63	15.54	*19.27	10.95	15.02	8.26	29' 70"
0				*37.27	23.26	*26.44	15.00	19.36	10.63	15.45	8.45	28' 10"
-5'	*33.78	*33.78	*36.59	23.19	*26.70	14.81	19.22	10.50	16.92	9.25	27' 20"	
-10'	*46.99	*46.99	*33.79	23.48	*25.12	14.93			*19.63	11.10	24' 40"	
-15'	*38.19	*38.19	*28.12	24.14					*20.76	15.61	19' 10"	

- Note
1. Ratings are based on SAE J1097
 2. The load point is a hook located on the back of the bucket.
 3. *Rated loads are based on hydraulic capacity.
 4. Rated loads do not exceed 87% of hyd. Capacity or 75% of tipping capacity.

- ☐ : Rating over front
- ☐☐ : Rating over side or 360 degree
- 0 : Ground

